



Mixstation

AA-88

INSTRUCTION MANUAL

Vestax Corporation

2-37-1 KAMIUMA, SETAGAYA-KU, TOKYO 154 JAPAN

CLASS 1 LASER PRODUCT
LUOKAN 1 LASERLAITE
KLASS 1 LASERAPPARAT

WARRANTY

The warranty might vary from country to country. Each distributor has their own warranty system in accordance with the country or state regulations or laws. VESTAX observes the manufacturing country's regulations.

FOREWORD

This section must be read carefully before any connection is made to the mains supply.

WARNINGS

- Do not expose the equipment to rain or moisture.
- Do not remove the cover from the equipment.
- Do not insert anything into the equipment through the ventilation holes.
- Do not handle the mains lead with wet hands.

CE marking



This product is in conformity with the EMC directive and low-voltage directive.

IMPORTANT

This apparatus is fitted with an approved moulded 13 Amp plug. To change a fuse in this type of plug proceed as follows:

1. Remove fuse cover and fuse.
2. Fix new fuse which should be a BS1362 5A, A.S.T.A. or BSI approved type.
3. Refit the fuse cover.

If the fitted plug is not suitable for your socket outlets, it should be cut off and an appropriate plug fitted in its place.

If the mains plug contains a fuse, this should have a value of 5A. If a plug without a fuse is used, the fuse at the distribution board should not be greater than 5A.

NOTE:

The severed plug must be destroyed to avoid a possible shock hazard should it be inserted into a 13A socket elsewhere.

HOW TO CONNECT A PLUG

The wires in the mains lead are coloured in accordance with the following code:

BLUE—"NEUTRAL" ("N")

BROWN—"LIVE" ("L")

1. The BLUE wire must be connected to the terminal which is marked with the letter "N" or coloured BLACK.
2. The BROWN wire must be connected to the terminal which is marked with the letter "L" or coloured RED.
3. Do not connect either wires to the earth terminal in the plug which is marked by the letter "E" or by the safety earth symbol  or coloured green or green-and-yellow.

Before replacing the plug cover, make certain that the cord grip is clamped over the sheath of the lead — not simply over the two wires.

COPYRIGHT

Recording and playback of some material may require permission. For further information refer to the following:

- Copyright Act 1956
- Dramatic and Musical Performers Act 1958
- Performers Protection Acts 1963, and 1972
- Any subsequent statutory enactments and orders

PRECAUTIONS

The following precautions should be taken when operating the equipment.

GENERAL PRECAUTIONS

When installing the equipment ensure that:

- the ventilation holes are not covered.
- air is allowed to circulate freely around the equipment.
- it is placed on a vibration-free surface.
- it will not be exposed to excessive heat, cold, moisture or dust.
- it will not be exposed to direct sunlight.
- it will not be exposed to electrostatic discharges.

In addition, never place heavy objects on the equipment.

If a foreign object or water does enter the equipment, contact your nearest dealer or service center.

Do not pull out the plug by pulling on the mains lead; grasp the plug.

It is advisable when leaving the house, or during a thunderstorm, to disconnect the equipment from the mains supply. Do not install the unit into a rack, etc. Doing so may prevent airventilation.

CONTENTS

FEATURES	4
BEFORE USE	4
CONTROLS, CONNECTIONS AND INDICATORS	6
Mixer Operation	7
Tuner Operation	9
CD Player Operation	10
MD Recorder Operation	13
REAR PANEL CONTROLS AND CONNECTIONS	18
BLOCK DIAGRAM	19
MD SYSTEM RESTRICTIONS	20
IN CASE OF TROUBLE	20
DISPLAYED MESSAGES	21
SPECIFICATIONS	22

FEATURES

- Built-in MD recorder with the recording/playback capabilities, CD player and a FM/AM tuner.
- Digital-to-digital recording from CD to MD.
- Individual faders for the 3 program input lines including the auxiliary input.
- Cross-fader across 2 program input lines.
- Built-in CD pitch controller.
- Stereo hi-fi specifications providing a 15 W + 15 W high quality sound.
- Light-emitting display panels showing accurate, easy-to-check information.

Some may believe that audio unit is simply a tool for playing good sound, and some may believe that it is a black-faced box which has the control panel on the front. The new concept of "Active Audio" presented by Vestax is a radical disappointment to those people who are enslaved by such a fixed idea. In special styling with which the controls including the fader controls are concentrated on the top panel and a MD recorder and CD player are built into the front panel, this super audio unit has been designed for the people who can enjoy audio in a positive manner by creating their own software MD discs, mixing sounds or doing DJ in their home studios, and connecting an analog disk turntable and cable broadcasting as well as karaoke microphones or musical instruments. Yes, here is the AA-88 "Mixstation".

BEFORE USE

Notes on the Compact Disc (CD)

The surface which is glossy like a rainbow is the front side of the CD, and the surface where the label information is printed is the back side.

Unlike conventional analog disk turntables, the CD player reads information from the disc by applying laser beam, in place of a stylus, on the front surface. Consequently, the performance of CD discs will not degrade after repeated use like conventional analog disks.

■ **Handle the CD disc carefully so as not to damage the front surface.**

■ **To maintain the CD disc flawless, do not place it in the following locations.**

- In a place subject to direct sunlight or near a heat source such as a room heater.
- In a place subject to excessive moisture or dirt.
- In a place which may be subject to rain, for example near a window.

■ **Keep the disc surface always clean.**

UP to about 6 billion items of data are recorded on the CD disc surface. When cleaning the disc surface, always use a specialized CD cleaner product and wipe in the direction as shown below.

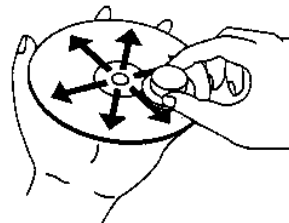

• Wipe in the radial direction.

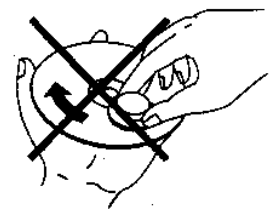

• Do not wipe in the circumference direction.

* Never use record cleaner designed for conventional analog disks, for this may degrade the CD disc surface.

■ **Always store disc properly in its case.**

Notes on the Mini Disc (MD)

The MD has a variety of features as described below.

1 High-quality recording

Direct digital recording of CD's digital signal ensures high-quality, clear sound.

2 High-speed access

The track number and recording information are recorded together with the audio tracks. This enables playing the desired track in an instant.

3 Repeated recording capability

Audio is recorded onto or played from the recording surface using a laser beam. The disc does not get cut or stretched like tape so it can be recorded onto as many times as required.

4 Same playback time as a CD from a smaller disc

Up to 74 minutes of recording is possible in a small disc cartridge of 71 mm x 68 mm. The same amount of music as a CD can be carried more handy.

5 Easy handling

The disc is accommodated in a cartridge, which is resistant to dust and scratches and easy to handle.

■ Do not touch the disc directly.

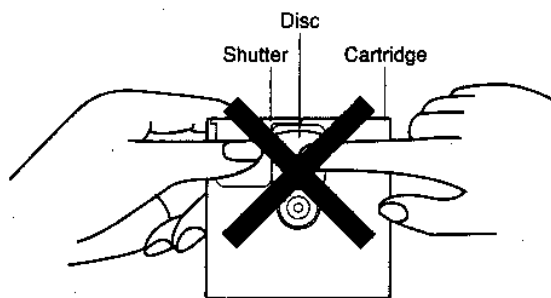

- Do not open the shutter and touch the disc directly.
- Do not force the shutter to open, otherwise it will be broken.

■ To protect a recorded MD from accidental erasure

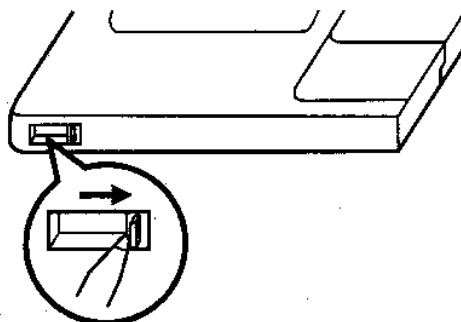

- Slide the protect tab on a side of the MD cartridge in the direction of the arrow to protect the disc from accidental erasure. (This action opens the tab opening.)
- When the disc is to be used for recording or editing, slide the protect tab back to the original position. (This action closes the tab opening.)

■ Caution in label attaching

Be sure to observe the following caution when attaching a label on a MD cartridge.

If the label is not attached properly, the cartridge may be stuck inside the unit and unable to be ejected.

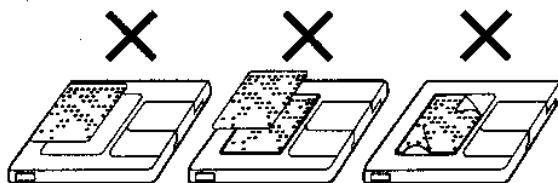

- Attach the label properly in the specified position (within the specified area).
- Do not attach a label on an existing label.
- If the label is partially peeled off or separated from the cartridge surface, remove it and attach a new label.

■ Caution for disc storage

Always store the MD disc in its case.

Do not leave the MD in the following locations.

- In a place subject to extended exposure to direct sunlight (particularly in a closed automobile).
- In a place subject to high temperatures or humidity.
- In a place where sand or dust may easily penetrate the cartridge (on the beach or sandy land).

CONTROLS, CONNECTORS AND INDICATORS

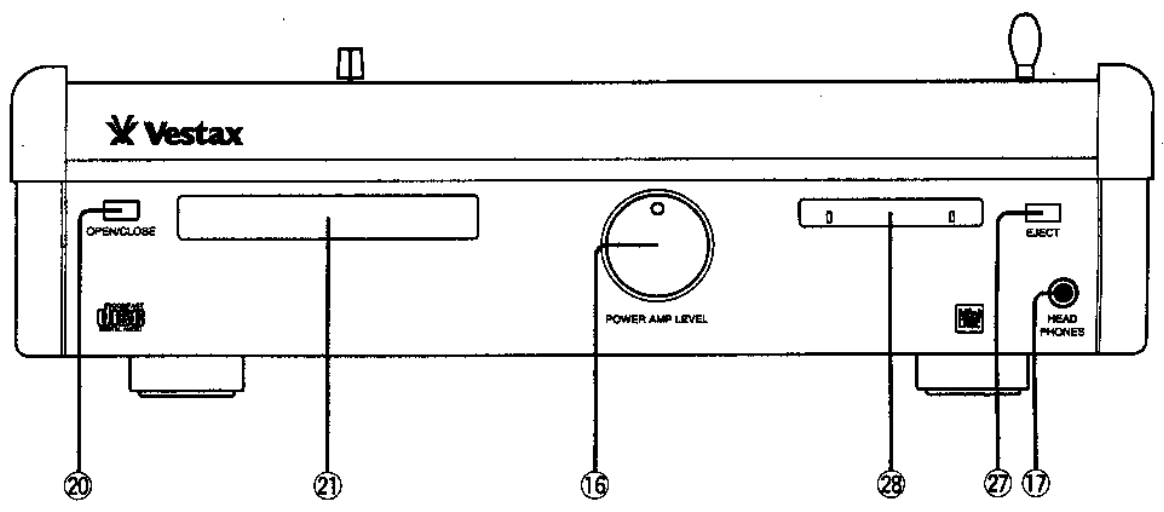
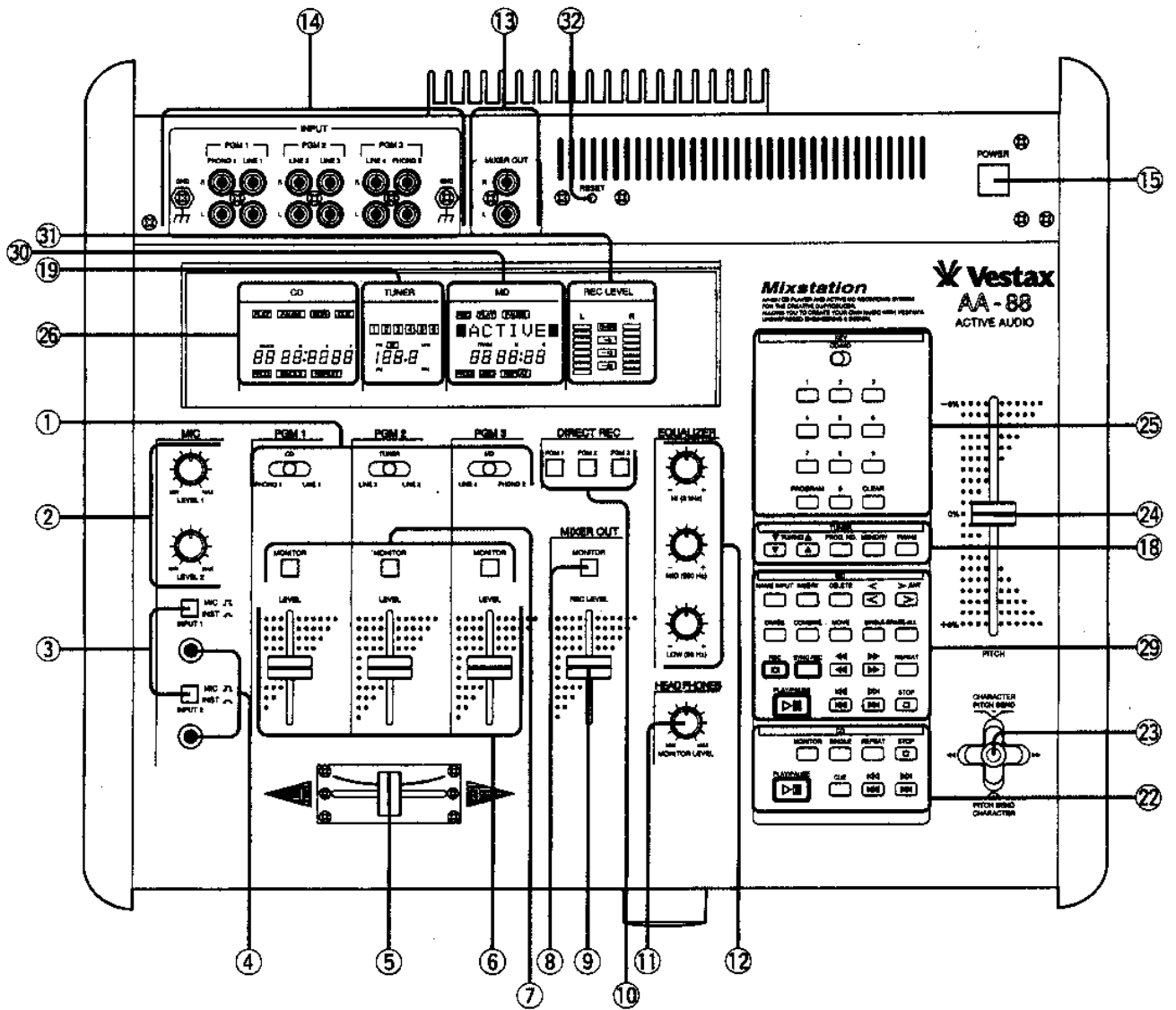

Mixer Operation

① PGM input selector switches

These levers select the program input sources. The sources which can be selected include the external source input to the PGM input jacks, the built-in CD player, the built-in MD recorder and the built-in tuner.

Set the lever of each PGM input selector switch to the desired position. This selects the source indicated in that position.

② MIC level controls

These knobs adjust the microphone volumes.

Turning each knob clockwise increase the volume of each microphone and counterclockwise to decrease it.

③ MIC / INST switches (MIC / INST)

Each of these buttons selects whether a microphone or musical instrument (such as an electronic keyboard) is connected to each microphone/musical instrument input jack. Press the button in to "INST" when connecting a musical instrument to the corresponding microphone/musical instrument input jack, or out to "MIC" when connecting a microphone.

④ Microphone/musical instrument input jacks

Connect microphones or musical instruments to these jacks.

⑤ Cross-fader

This control knob adjusts the ratio of mixing between the PGM 1 and PGM 3 sources.

Setting the cross-fader to position "1" maximizes the PGM 1 source level and minimizes the PGM 3 source level in the mixing.

Setting the cross-fader to position "3" maximizes the PGM 3 source level and minimizes the PGM 1 source level in the mixing.

* When noise during the cross-fader operation becomes noticeable, replace it with the replacement cross-fader unit "CF-RG".

The cross-fader can be replaced with the following procedure.

- 1 Remove the fader unit retaining screws (x 4) and the slide knob.
- 2 Take out the fader unit.
- 3 Remove the multi-cable connector from the fader unit.
- 4 Attach the connector to the new fader unit and secure the panel using the retaining screws.

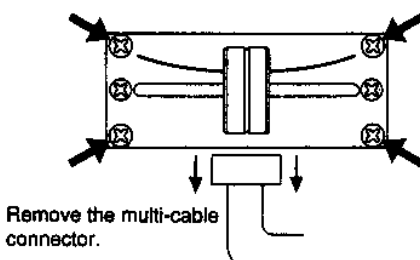

⑥ PGM LEVEL faders

These control knobs adjust the input levels of the PGM input sources.

Setting the fader to scale "10" maximizes the input level of the corresponding PGM source and to scale "1" minimizes it.

It is recommended to set it usually to around "7" and "8".

⑦ PGM MONITOR switches

These buttons select the sources monitored through headphones.

Pressing a MONITOR switch allows to monitor the corresponding PGM input source through headphones.

When more than one MONITOR switch is pressed together, the sources of more than one PGM input channel are mixed and output through headphones.

⑧ MIXER OUT MONITOR switch

Press the button to monitor the mixer output through headphones.

⑨ REC LEVEL fader (MIXER OUT level fader)

This knob adjusts the mixer output level as well as the recording level of the built-in MD recorder.

The output level is maximized at scale "10" and minimized at scale "1".

Adjust the fader so that the OVER segment of the REC LEVEL meter does not light.

NOTE:

When adjusting the listening volume, first adjust the REC LEVEL fader so that the REC LEVEL meter indicates a proper level then adjust the power amplifier's level control for an optimum listening level.

If it is not adjusted as described above, noise will increase, deteriorating the S/N ratio or distorting audio.

⑩ DIRECT REC switches

These buttons allow to record the PGM input sources on the built-in MD recorder directly, that is, without passing the signals through the cross-fader and equalizer circuitry.

When a DIRECT REC switch is pressed in, the source of the corresponding PGM input channel is fed directly to the built-in MD recorder. Pressing more than one button allows to record the mixing of more than one channel.

If none of the DIRECT REC switches is pressed, the mixer output is selected as the MD recorder input source.

⑪ HEADPHONES level control

This knob adjusts the headphones volume. Turn the knob clockwise to increase the volume and counterclockwise to decrease it.

NOTE:

No signal is output to the headphones while none of MONITOR switches ⑦ and ⑧ is pressed.

⑫ EQUALIZER controls

These knobs are used for the equalizer adjustment of the mixer output.

The HI control varies the high-frequency level, the MID control varies the medium-frequency level and the LOW control varies the low-frequency level.

No equalizing effect is provided when the EQUALIZER controls are set to the center positions. Turning a control knob clockwise from the center boosts the corresponding frequency band and counterclockwise from the center attenuates it.

⑬ MIXER OUT jacks

These jacks output the audio mixed by the mixer circuitry. Connect to an external power amplifier if this is in use.

NOTE:

When DIRECT REC switches ⑩ are pressed in, the audio signals are output by bypassing the cross-fader and equalizer circuitry.

⑭ INPUT jacks

These jacks are used to connect external components.

PGM 1 : PHONO 1 or LINE 1

PGM 2 : LINE 2 or LINE 3

PGM 3 : LINE 4 or PHONO 2

NOTE:

The PHONO inputs accept analog disk turntables, and the LINE inputs accept a tape deck, MD recorder, CD player, etc. If a wrong component is connected, the listening volume may be insufficient or audio may be distorted. The connected analog disk turntable should use a MM cartridge.

⑮ POWER switch (OFF / ON)

Press the button to turn the power ON and press again to turn it OFF.

⑯ POWER AMP LEVEL control

This knob adjusts the volume of the built-in power amplifier. Turn the knob clockwise to increase the volume and counterclockwise to decrease it.

⑰ HEADPHONES jack

Plug headphones into this jack.

The headphones should have an impedance between 8 and 600 ohms.

Do not use headphones with other impedance, for the listening volume may be insufficient or audio may be distorted.

Tuner Operation

18 TUNER controls

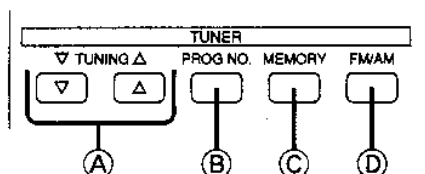

Ⓐ TUNING buttons (▼/▲)

Press the ▼ button to decrease the frequency by one step. Press the ▲ button to increase the frequency by one step. Press and hold a TUNING button for more than 0.5 second to start automatic tuning, which stops automatically when a strong radio wave of broadcasting is detected. Press the ▼, ▲, (PROG. NO.) or (FM/AM) button to stop automatic tuning. The frequency varies continually while the TUNING button is held depressed.

Ⓑ PROG. NO. button

Press to select one of the stations which have been preset in memory or to preset a station in memory. Each press of the (PROG. NO.) button changes the program number in cycle of [1-2-3-4-5-6].

Ⓒ MEMORY button

Press when presetting a station in memory.

Ⓓ FM/AM tuner band button

Press to switch the tuner band.

Each press of the (FM/AM) button alternates the band between AM and FM.

19 Tuner display

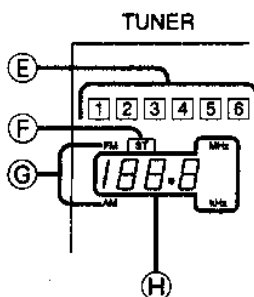

Ⓔ Program indicators

One of the program numbers light when the PROG NO. button is pressed or during preset memory tuning.

Ⓕ Stereo indicator

Lights when FM stereo broadcasting is tuned in.

Ⓖ Band Indicators

"FM" lights during reception of FM broadcasting and "AM" lights during reception of AM broadcasting.

Ⓗ Frequency display

Shows the frequency being tuned.

■ Preset memory tuning

- 1 Press the (FM/AM) button to select the desired band (FM or AM).
- 2 Press the (PROG. NO.) button to select the program number in which the desired station has been preset in memory.

■ Preset memory procedure

The frequency of a desired station can be preset as described below.

- 1 Press the (FM/AM) button to select the desired band (FM or AM).
- 2 Press the (PROG. NO.) button to select the program number to preset the desired station.
- 3 Press the ▼ or ▲ TUNING button to tune in the frequency of the desired station.
- 4 Press the (MEMORY) button.
A program number indicator blinks.
- 5 Press the (MEMORY) button again.

The program number indicator stops blinking and starts to light steadily to indicate the completion of the memory operation.

* To abort the memory operation in the middle, press the ▼ or ▲ TUNING button or the (FM/AM) button. The blinking changes to steady lighting and the memory operation is aborted.

The memory operation can also be aborted by leaving the unit untouched for 10 seconds during the above procedure.

NOTE:

The frequencies preset in the program memory are held for about a week after the AA-88 has been turned OFF. However, if it has not been used for a long period of time, the memory frequencies will be reset to the factory setup.

CD Player Operation

① OPEN/CLOSE button

This button is used to change the CD disc played.

Pressing the **OPEN/CLOSE** button while the CD tray is closed opens it.

Pressing the **OPEN/CLOSE** button while the CD tray is open closes it.

* When changing a CD, place the new CD with the label facing up and correctly along the groove on the tray before closing the tray.

② CD tray

Place a CD disc with the label surface facing upward.

③ CD controls

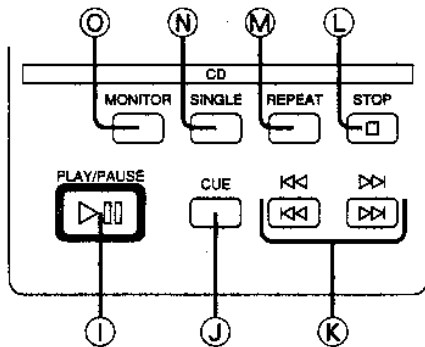

① PLAY/PAUSE button

Press to play a CD or let CD playback pause.

② CUE button

This button is used to locate the beginning of a phrase in music and, by pressing the **PLAY/PAUSE** button and this button alternately, it is also possible to play a phrase repeatedly.

When the **PLAY/PAUSE** button is pressed during pause, the position where playback pauses is stored in memory as frame data and the CUE indicator in the CD display area turns on. Later, when the **CUE** button is pressed, the playback position returns to the position stored in memory and playback pauses there. Now pressing the **PLAY/PAUSE** button starts normal playback from the position in memory. The cue point memory is always updated to the position where pause was released last, and the previous cue point is cleared automatically. The CUE indicator lights during the memory storage operation. The cue point memory is cleared when the unit returns to stop mode; the CUE indicator turns off at this moment.

③ Skip buttons (**⏮** / **⏭**)

⏮ : Press during playback to skip to the beginning of the track being played and start to play it again. The next press skips to the beginning of the previous track to it and starts to play that track.

⏭ : Press during playback to skip to the beginning of the next track and play it.

④ STOP button

Press to stop CD playback.

When the **STOP** button is pressed during CD playback, the PLAY indicator in the CD display area turns off and playback stops.

⑤ REPEAT button

Press to activate repeat playback.

When the **REPEAT** button is pressed, the REPEAT indicator in the CD display area turns on and repeat playback starts. When the last track on the disc has been played in the repeat playback, playback is repeated from the first track.

Press the **REPEAT** button again to cancel repeat playback. The REPEAT indicator turns off and the repeat playback is canceled.

⑥ SINGLE play button

This button is used to play only a single track or to repeat only a single track.

• Single-track play

Press the **SINGLE** button during playback. The SINGLE indicator in the CD display area turns on and, when the track being has completed, the playback returns to the beginning of the same track and enters pause mode there.

Press the **SINGLE** button again to cancel single track play. The SINGLE indicator turns off and the single track play is canceled, but the pause mode continues.

• Single-track repeat

Press the **SINGLE** button then the **REPEAT** button. The SINGLE and REPEAT indicators in the CD display area light and the track being played is repeated.

⑦ MONITOR button

Press in pause mode to repeat the section around the pause position repeatedly. The sound monitored in this way can be used as the reference in searching the cue point of a musical phrase, etc.

When the **MONITOR** button is pressed in pause mode, the MONITOR indicator in the CD display area turns on and the sound around the pause position will be played repeatedly.

To cancel the monitor operation, press the **MONITOR** button again. The MONITOR indicator turns off and the playback of the surroundings of the pause position stopped.

The monitor operation can be canceled only by pressing the **MONITOR** button again. While the MONITOR indicator in the CD display area is lit, the sound of a pause position is played repeatedly any time the CD player enters pause mode.

23 Joystick control

Tilting the joystick up or down varies the pitch (PITCH BEND) and tilting it to the left or right allows to scan the play (fast forward/fast reverse).

The pitch can be varied by up to $\pm 8\%$.

* The pitch value when the joystick is in the PITCH BEND center position is equal to the value set by the PITCH fader. If the PITCH fader is set to the $+8\%$ or -8% position, the pitch cannot be varied over $+8\%$ or below -8% even by varying the PITCH BEND function.

24 PITCH fader

This knob varies the CD playback speed by up to $\pm 8\%$. The CD playback speed is normal when the PITCH fader is in the center position. The speed increases when the fader is slid toward + and decreases when it is slid toward -.

25 CD/MD controls

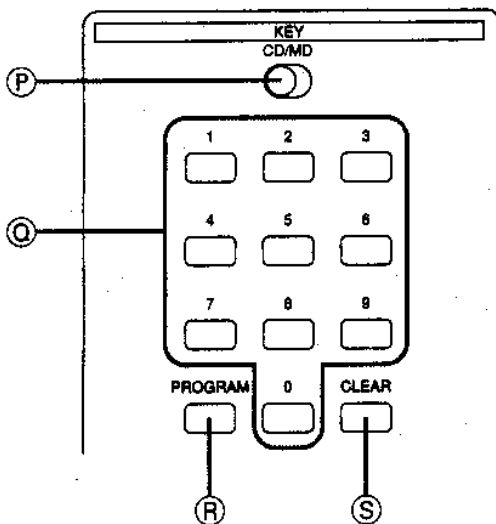

Ⓟ CD/MD switch

This switch whether the direct numeric buttons, PROGRAM button and CLEAR button below are to control the CD player or MD recorder.

Set the switch to CD to control the CD player or to MD to control the MD recorder.

Ⓠ Direct numeric buttons

Press these buttons to select a track to be played or programmed directly by its number.

Ⓡ PROGRAM button

Press to program CD or MD tracks.

Ⓢ CLEAR button

Press to clear a CD or MD program or a disc or track name.

26 CD display area

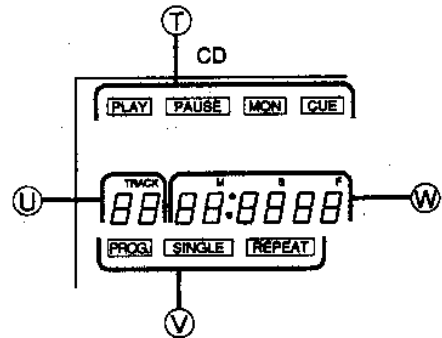

Ⓣ PLAY/PAUSE/MON/CUE Indicators

PLAY : Lights in play mode.

PAUSE : Lights in pause mode.

MON : Lights when the monitor function is set.

CUE : Lights when a cue point is set.

Ⓤ TRACK number display

Shows the track number during playback, the total number of tracks in stop mode, and the number of programmed tracks during programming.

Ⓥ PROG./SINGLE/REPEAT Indicators

PROG. : Lights when tracks are programmed.

SINGLE : Lights in single-track play mode.

REPEAT : Lights in repeat mode.

Ⓦ Time display

Shows the remaining play time of a track (in min. and sec.) and the frame number.

■ Playing a CD

- 1 If the AA-88 is OFF, press the POWER switch to turn it ON.
- 2 Press the **OPEN/CLOSE** button to open the CD tray and place a disc with the label side facing upward.
- 3 Close the CD tray by pushing its front lightly or pressing the **OPEN/CLOSE** button.
- 4 Press the CD **PLAY/PAUSE** button.
The PLAY indicator in the CD display area turns on, the track number and remaining play time of the track are displayed, and playback starts from the first track. When the last track has been played, playback stops automatically.

■ To let playback pause temporarily

Press the CD **PLAY/PAUSE** button during playback. The PLAY indicator in the CD display area turns off, the PAUSE indicator turns on and the CD player enters pause mode. To cancel pause and resume playback, press the CD **PLAY/PAUSE** button again. The PLAY indicator in the CD display area turns on, the PAUSE indicator turns off and pause is canceled.

■ To stop playback

Press the CD **STOP** button.
The PLAY indicator in the CD display area turns off and playback stops.

■ In case of trouble in CD playback

A CD cannot be read.	<ul style="list-style-type: none"> • The built-in CD player can play only the music CD (CD-DA). It cannot play a VIDEO CD or a CD-ROM. • A scratched or dirty disc may sometimes be unable to be played. • When the AA-88 is used in a place with high humidity or when it is cooled suddenly, condensation may occur on the CD lens, in which case playback is not possible.
The CD sound skips.	<ul style="list-style-type: none"> • Normal playback may sometimes be impossible if the disc is scratched or dirty. • Normal playback may sometimes be impossible if the AA-88 is subjected to strong shock or vibration.
The CD sound is not output.	<ul style="list-style-type: none"> • Is a CD being played? → Check that the PLAY indicator in the CD display area ⑫ is lit. • Check that the PGM 1 input selector switch ① is set to CD. • Check that speakers are connected to the SPEAKER SYSTEM terminals ⑮ or that the external power amplifier is connected to the MIXER OUT jacks ⑬. • Check that the cross-fader ⑤ is set to the <1 or center position. • Are the level controls of ⑥, ⑨ and ⑩ in the minimum positions? → If so, adjust them to proper levels.

■ Programmed playback of CD

- 1 Place a CD on the CD tray.
- 2 Set the CD/MD switch to CD.
- 3 Press the **PROGRAM** button while the CD player is in stop mode.
- 4 Select the first track to be programmed by composing its number with the direct numeric buttons.
- 5 Press the **PROGRAM** button.
To program other tracks, repeat steps 3 to 5 for each.
- 6 After having programmed all desired tracks, press the **PROGRAM** button once again to enter the program in memory and put the CD player in stop mode.
The PROG indicator in the CD display area stops blinking and starts to light steadily.
- 7 Press the CD **PLAY/PAUSE** button.
Tracks will be programmed in the order they are programmed.
* Up to 20 tracks can be programmed.

● To check the program

After the tracks have been programmed, they can be checked by pressing the skip **⏮** or **⏭** button.

● To clear the program

- 1 Press the **PROGRAM** button.
The PROG indicator in the CD display area blinks.
- 2 Press the **CLEAR** button.
* The program is cleared also when the CD tray is opened, the AA-88 is turned OFF or the **PROGRAM** button is pressed again.

MD Recorder Operation

㉗ EJECT button

Press to eject the MD cartridge.

㉘ MD holder

Insert an MD disc here.

㉙ MD controls

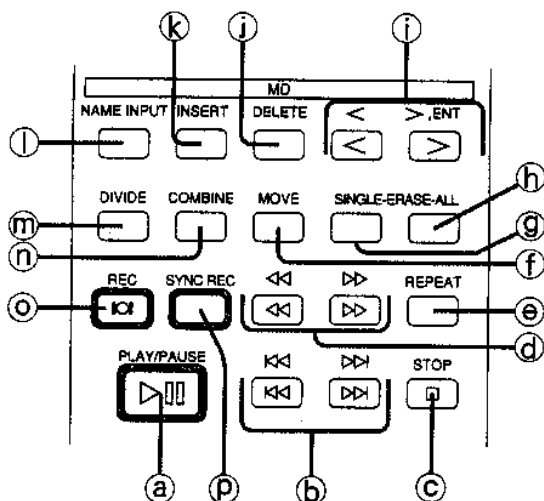

㉚ PLAY/PAUSE button

Press to play a MD or let MD recording/playback pause.

㉛ Skip buttons (<< / >>)

<<< : Press during playback to skip to the beginning of the track being played and start to play it again. The next press skips to the beginning of the previous track to it and starts to play that track.

>>> : Press during playback to skip to the beginning of the next track and play it.

㉜ STOP button

Press to stop MD playback.

When the **STOP** button is pressed during MD playback, the PLAY indicator in the MD display area turns off, playback stops and the MD display area shows the disc name, total number of tracks and the total remaining play time.

㉝ Search buttons (<<< / >>>)

<<<< : Press and hold this button during playback to search the track being played in the backward direction.

>>>> : Press and hold during playback to search the track being played in the forward direction.

* Pressing a search button during pause also changes the played position forward or backward at a high speed but, as the sound is not produced during this, the desired position should be searched by referring to the time information. The MD recorder enters pause mode at the moment the button is released.

㉞ REPEAT button

Press to activate repeat playback.

When the **REPEAT** button is pressed, the REPEAT indicator in the MD display area turns on and repeat playback starts. When the last track on the disc has been played in the repeat playback, playback is repeated from the first track. Press the REPEAT button again to cancel repeat playback. The REPEAT indicator turns off and the repeat playback is canceled.

㉟ MOVE button

Use this button to change the order of tracks.

㊱ SINGLE ERASE button

Press to erase a single track from a MD disc.

㊲ ALL ERASE button

Press to erase all tracks in a MD disc.

㊳ Cursor buttons

< : Press during name input operation to move the cursor toward the left.

>, ENT : • Press during name input to move the cursor toward the right.
• Press to enter the editing results in memory.

㊴ DELETE button

Press to delete a character.

㊵ INSERT button

Press to insert a space.

㊶ NAME INPUT button

Use this button to assign a name to a disc or track.

㊷ DIVIDE button

Press to divide a track into two before and after a desired position.

㊸ COMBINE button

Press to combine two consecutive tracks into a single track.

㊹ REC button

Press for normal recording.

㊺ SYNC REC button

Press for starting and stopping MD recording in synchronism with the playback of the built-in CD player. (Digital-to-digital recording)

⑩ MD display area

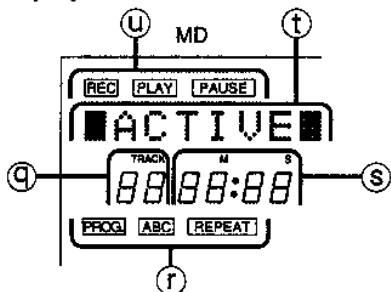

⑨ TRACK number display

Shows the track number during playback, the total number of tracks in stop mode, and the number of programmed tracks during programming.

① PROG./ABC/REPEAT Indicators

PROG. : Lights when tracks are programmed.

ABC : Lights during character input operation.

REPEAT : Lights in repeat mode.

⑤ Time display

Shows the remaining play time of a track during playback and the remaining recording time of a disc during recording.

① Character display

Shows the name of a disc or track.

④ REC/PLAY/PAUSE indicator

REC : Lights in record mode.

PLAY : Lights in play mode.

PAUSE : Lights in pause mode.

③ Recording level meter

Shows the recording level.

② RESET button

See "IN CASE OF TROUBLE" on page 20.

■ Playing a MD

- 1 If the AA-88 is OFF, press the POWER switch to turn it ON.
- 2 Hold a disc with the label side facing upward and insert into the MD holder in the direction indicated by the arrow on the disc cartridge. In a little while, the MD information (disc name, track name and the total play time of the disc) will be displayed in the MD display area.
- 3 Press the MD **PLAY/PAUSE** button.
The PLAY indicator in the MD display area turns on, the track number, track name and remaining play time of the track are displayed, and playback starts from the first track. When the last track has been played, playback stops automatically.

* If a MD disc containing more than 100 minutes of recording or the MD tracks has been programmed into a program with longer play time than 100 minutes, the displayed time information may not be correct.

Up to 99 tracks can be played in MD playback.

■ To let playback pause temporarily

Press the MD **PLAY/PAUSE** button during playback. The PLAY indicator in the MD display area turns off, the PAUSE indicator turns on and the CD player enters pause mode.

To cancel pause and resume playback, press the MD **PLAY/PAUSE** button again. The PLAY indicator in the MD display area turns on, the PAUSE indicator turns off and pause is canceled.

■ To stop playback

Press the MD **STOP** button.

The PLAY indicator in the MD display area turns off and playback stops.

■ Recording a MD

- 1 Insert a disc, with the label side facing upward, into the MD holder in the direction indicated by the arrow on the disc cartridge.
- 2 Check the source input level on the REC LEVEL meter, adjust the recording level with the REC LEVEL fader.

NOTES:

- Adjust the recording level to the maximum level provided that the OVER segment of the REC LEVEL meter does not light.
 - In sync recording from the built-in CD player on MD, the recording level is set automatically to same level as the CD playback level.
As a result, it is not required to adjust the recording level of sync recording.
 - 3 Press the **REC** button.
The REC and PAUSE indicators in the MD display area turn on and the MD recorder enters record-pause mode.
 - 4 Press the MD **PLAY/PAUSE** button.
The PAUSE indicator in the MD display area turns off and recording starts.
 - Track numbers are assigned automatically by leaving a blank of 1.5 second or more between tracks.
 - The DIRECT REC switches make it possible to record directly the sources of the PGM channels corresponding to the pressed switches, without processing them through the cross-fader and equalizer circuitry.
- * MD recording is not possible if 99 or more tracks have already been recorded or the remaining recording time is very short.

● **To record MD from the middle of previously-made recording**

- 1 Press the MD **PLAY/PAUSE** button during MD playback. The PAUSE indicator in the MD display area turns on and the MD recorder enters pause mode.
- 2 Press the **REC** button.
"REC Erase OK" appears in the MD display.
- 3 Press the **>ENT** button.
The REC and PAUSE indicators in the MD display area turn on and the MD recorder enters record-pause mode.
- 4 Press the MD **PLAY/PAUSE** button.
The PAUSE indicator in the MD display area turns off and recording starts.

NOTE:

At the moment the MD recorder enters record-pause mode, the recording after that position is erased entirely.

■ **Erasing tracks**

● **To erase track by track (single-track erasure)**

The specified track can be erased with the following procedure. (The track title is also cleared.)

- 1 In stop mode, specify the track number to be erased by pressing direct numeric buttons or one of the MD skip buttons.
- 2 Press the **SINGLE ERASE** button.
"Single Erase OK?" appears in the MD display.
- 3 Press the **>ENT** button.
"Erase OK?" blinks in the MD display.
- 4 Press the **>ENT** button again.
"Complete" appears in the MD display and the specified track is erased.
* To cancel the operation in the middle, press the **CLEAR** button or the MD **STOP** button.

● **To erase all tracks (all-track erasure)**

All tracks on a MD disc can be erased with the following procedure. (The disc and track names are also cleared.)

- 1 The MD recorder should be in stop mode.
- 2 Press the **ALL ERASE** button.
"All Erase OK?" appears in the MD display.
- 3 Press the **>ENT** button.
"Erase OK?" blinks in the MD display.
- 4 Press the **>ENT** button again.
"Complete" appears in the MD display and all tracks are erased.
* To cancel the operation in the middle, press the **CLEAR** button or the MD **STOP** button.

■ **Sync recording (digital-to-digital recording)**

● **Normal sync recording**

The built-in MD recorder of the AA-88 can record the signals from the built-in CD player in synchronism with the start and stop of CD playback.

- 1 Load a CD and a MD.
- 2 Press the **SYNC REC** button.
The PAUSE indicator in the CD display area and the REC and PAUSE indicators in the MD display area blink. They stop blinking and start to light steadily when the AA-88 gets ready for starting recording.
- 3 Press the MD **PLAY/PAUSE** button or the CD **PLAY/PAUSE** button.
To stop sync recording, press the MD **STOP** button or the CD **STOP** button.

● **Programmed sync recording**

Program desired CD tracks first. → P. 16

Then start normal sync recording. The programmed CD tracks will be recorded in the order they are programmed. To stop programmed sync recording, press the MD **STOP** button.

- During sync recording, the track number recorded on the MD changes automatically when that of the CD changes.
- When the CD playback completes, both the CD player and MD recorder stop automatically. (The MD recorder may not stop automatically with certain CD discs.)
* Sync recording is possible only from the CD source.

■ **Programmed playback of MD**

- 1 Insert a CD in the MD holder.
- 2 Set the CD/MD switch to MD.
- 3 Press the **PROG. NO.** button while the MD recorder is in stop mode.
- 4 Select the first track to be programmed by composing its number with the direct numeric buttons.
- 5 Press the **PROG. NO.** button.
To program other tracks, repeat steps 3 to 5 for each.
- 6 After having programmed all desired tracks, press the **PROG. NO.** button once again to enter the program in memory and put the MD recorder in stop mode.
The PROG indicator in the MD display area stops blinking and starts to light steadily.
- 7 Press the MD **PLAY/PAUSE** button.
Tracks will be programmed in the order they are programmed.
* Up to 20 tracks can be programmed.

● **To check the program**

After the tracks have been programmed, they can be checked by pressing the skip **◀◀** or **▶▶** button.

● **To clear the program**

- 1 Press the **PROG. NO.** button.
The PROG indicator in the MD display area blinks.
- 2 Press the **CLEAR** button.

* The program is cleared also when the MD is ejected, the AA-88 is turned OFF or the **PROG. NO.** button is pressed again.

Editing of MD

The MD recorder incorporates the following editing functions that allow you to create original discs by reordering MD tracks, assigning disc and track names and so on.

■ Division (DIVIDE)

This function divides a track into two tracks at the desired position.

- 1 Play the track to be divided. When the position where you want to divide the track comes, press the **(PLAY/PAUSE)** button to enter pause mode.
- 2 Press the **(DIVIDE)** button.
"Divide?" appears in the MD display.
- 3 Press the **(>,ENT)** button.
"Complete" appears in the MD display and the track is divided. The MD recorder enters stop mode at the beginning of the latter track obtained by division.
 - The track numbers after the divided track are increased by one.
 - The two tracks obtained by division have the same track names.
 - Tracks can be divided until the total number of tracks on a MD reaches 99. However, even when it is less than 99, no more division is available if "TOC Full" is displayed.
 - The DIVIDE function is not available when the PROG indicator is lit.
 - To abort division in the middle, press the **(CLEAR)** button or the MD **(STOP)** button.

■ Combination (COMBINE)

This function combines two consecutive tracks into a single track.

- 1 Play the latter track of the two tracks and press the **PLAY/PAUSE** button to enter pause mode.
- 2 Press the **(COMBINE)** button.
"Combine?" appears in the MD display.
- 3 Press the **(>,ENT)** button.
"Complete" appears in the MD display and the current track is combined with the tracks located before it. The MD recorder enters stop mode at the beginning of the track obtained by combination.
 - The track numbers after the combined tracks are decreased by one.
 - It is not possible to combine a track recorded from CD or MD by means of digital recording (or sync recording) with a track recorded from the analog input.
 - A shorter track than 15 seconds may sometimes not be possible to be combined with another track.
 - The new track obtained by combination has the same name as the former track before combination. However, if the former track did not have the track name, the track name of the latter track is assigned to the new track.
 - The COMBINE function is not available when the PROG indicator is lit.
 - To abort combination in the middle, press the **(CLEAR)** button or the MD **(STOP)** button.

■ Movement (MOVE)

This function moves the specified track to a desired position.

- 1 Press the **(STOP)** button to enter stop mode.
- 2 Press the **(MOVE)** button.
"MOV >" appears in the MD display.
- 3 Specify the track number to be moved and press the **(MOVE)** button.
"MOV □ >" (where □ is the track number specified to be moved) appears in the MD display.
- 4 Specify the new track number of the movement destination and press the **(MOVE)** button.
"MOV □ > ○" (where ○ is the track number specified as the move destination) appears in the MD display.
- 5 Press the **(>,ENT)** button.
"Complete" appears in the MD display and the specified track is moved.
 - The MOVE function is not available when the PROG indicator is lit.
 - To abort movement in the middle, press the **(CLEAR)** button or the MD **(STOP)** button.
 - * If no button has been pressed for 10 seconds during an editing operation other than the disc and track name input, the operation is canceled automatically.

In case of power failure

The disc's TOC (Table of Contents) data updated by recording or editing is written later in the disc. If there is a power failure or the Power cord is disconnected from the AC power outlet before the writing takes place, the updated TOC data is written in the disc the next time the AA-88 is turned ON.

NOTE:

The TOC data which failed to be written due to power failure is held for about 3 days. If the AA-88 is not used for a longer period than this, the held TOC data is cleared and cannot be written in the disc.

■ Assigning the disc and track names

1 The disc name can be assigned while the MD recorder is put to stop mode by pressing the MD (STOP) button. The track name can be assigned during recording, by playing the track to be named, during pause of the track, or by setting the CD/MD switch to MD and specifying the track with the direct numeric buttons.

2 Press the (NAME INPUT) button to enter the MD disc and track name input mode.

3 Select the character type by tilting the joystick control up and down.

Tilting the joystick downward changes the character types in the following sequence.

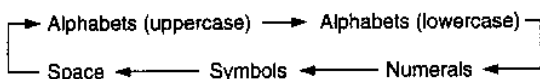

Tilting the joystick upward changes them in the reverse sequence.

4 Tilt the joystick to the left or right until the desired character is displayed.

5 Press the (>ENT) cursor button. The AA-88 becomes ready for the input of the next character.

6 Input other disc or track name characters by repeating steps 3 to 5 for each.

7 Press the (NAME INPUT) button. "Complete" appears in the MD display and the name input mode terminates.

- A disc can contain a disc name and up to 99 track names.
- Each disc or track name can be composed of up to 80 characters. "Name Full" appears in the MD display if more than 80 characters are input. When "Name Full" appears, delete the excessive characters.
- A disc can contain up to about 1700 characters including the disc and track names. "TOC Full" appears in the MD display if the maximum number of characters is exceeded.
- The maximum number of characters reduces if Japanese katakana characters are input.
- The Japanese katakana characters input with the AA-88 may not be displayed correctly with other MD recorder product. Also, when a disc in which Japanese katakana characters were input with another product is used, they may not be displayed correctly on the AA-88.
- When the track name is input during playback, the MD recorder enters single-track repeat mode of the track. However, the REPEAT indicator does not turn on in this case.
- To abort the disc or track name input in the middle, press the MD (STOP) button.

■ Correcting the disc or track name

● Correction by overwriting

1 Perform steps 1 and 2 of "Assigning the disc and track names", then press the (<) or (>ENT) cursor button so that the character to be corrected blinks.

2 Tilt the joystick to select the correct character.

3 Press the (NAME INPUT) button to complete the disc or track name input.

● Correction by insertion

1 Perform steps 1 and 2 of "Assigning the disc and track names", then press the (<) or (>ENT) cursor button so that the character to be corrected blinks.

2 Press the (INSERT) button to insert a space.

3 Tilt the joystick to select the correct character.

4 Press the (NAME INPUT) button to complete the disc or track name input.

● Deletion of a character

1 Perform steps 1 and 2 of "Assigning the disc and track names", then press the (<) or (>ENT) cursor button so that the character to be corrected blinks.

2 Press the (DELETE) button.

3 Press the (NAME INPUT) button to complete the disc or track name input.

* Pressing the (CLEAR) button erases all of the input characters.

■ Available character types

Character Type	Available Characters
Alphabets (uppercase)	A B C D E F G H I J K L M N O P Q R S T U V W X Y Z
Alphabets (lowercase)	a b c d e f g h i j k l m n o p q r s t u v w x y z
Numerals	0 1 2 3 4 5 6 7 8 9
Symbols	! " # \$ % & ' () * + , - . : ; < > ? @ [\] ^ _ ` { } ~

□ : Space

REAR PANEL CONTROLS AND CONNECTIONS

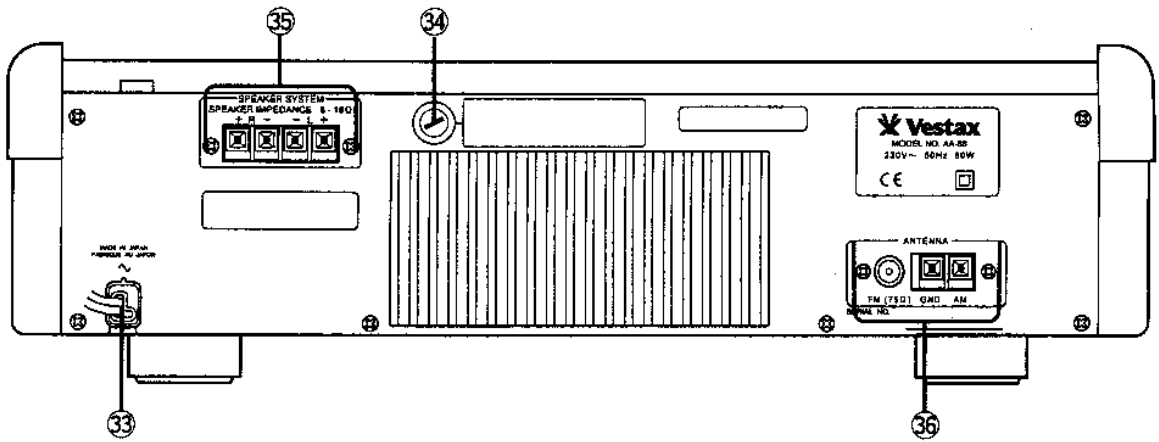

33 Power cord

Plug into the wall outlet of household power supply (120 V AC).

34 Fuse holder

Use a fuse rated 1.6 A, 125 V. If the fuse is blown, replace with a fuse with the same rating.

35 SPEAKER SYSTEM terminals

Connect speakers with an impedance from 8 to 16 ohms.

36 ANTENNA terminals

Connect antennas to these terminals.

* Preparing the AM LOOP antenna

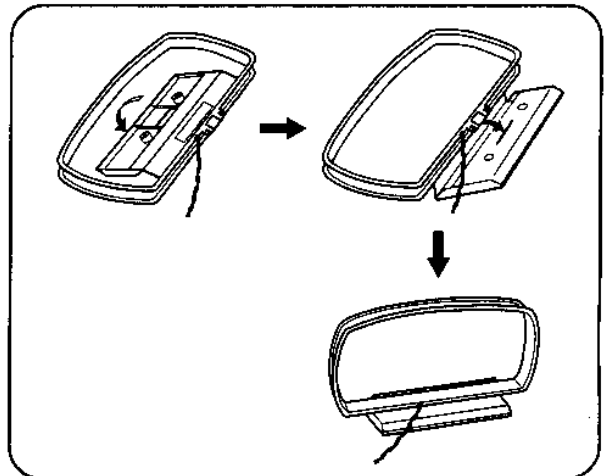

BLOCK DIAGRAM

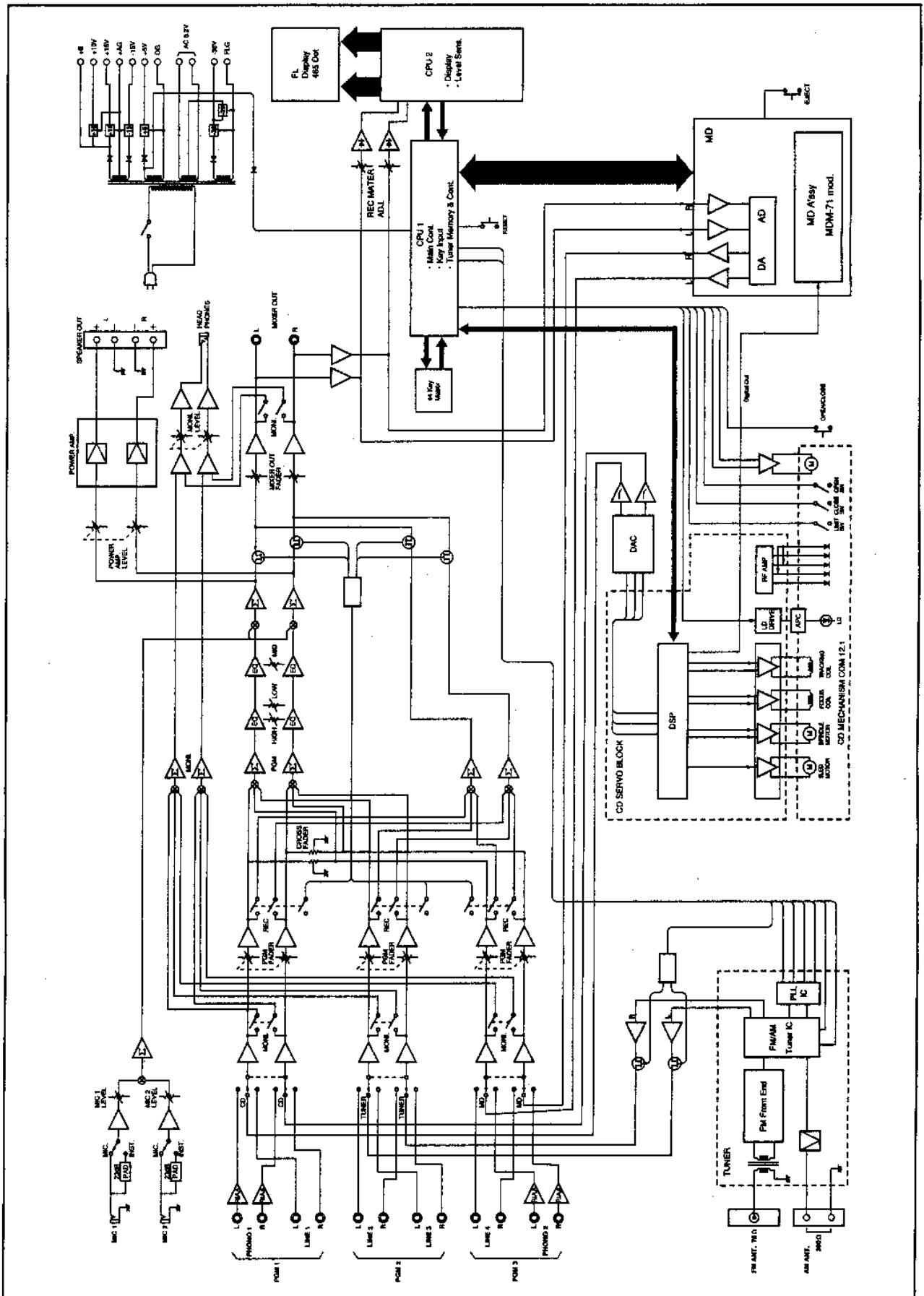

MD SYSTEM RESTRICTIONS

The MD is recorded with a different format from conventional analog tapes or the DAT. As a result, the following incidents may be observed depending on the way you record or edit it.

These incidents are caused due to the restrictions of the MD system and are not malfunctions.

<p>"TOC Full" may be displayed before the maximum recording time of the MD is reached.</p>	<p>The MD system records the track delimitation data in the TOC. After repeated recording and editing by partially clearing the TOC data, the TOC sometimes becomes full before the number of tracks reaches the maximum (99 tracks), making no more recording possible. (Such a MD can be restored to the initial condition by using the all-track ERASE function.)</p>
<p>"Disc Full" may be displayed before the maximum recording time of MD is reached.</p>	<p>If the disc is scratched or otherwise damaged, the available recording time reduces because the damaged sections are made automatically unavailable for recording.</p>
<p>The remaining recording time does not increase even after having erased several short tracks.</p>	<p>When the remaining recording time of MD is calculated and displayed, shorter tracks than 12 seconds are sometimes excluded from the calculation.</p>
<p>The total of the time of existing recording and the remaining recording time does not make the maximum recording time of the MD.</p>	<p>The minimum unit of recording is usually a cluster (about 2 seconds), but shorter music than it is also recorded using a space of about 2 seconds. As a result, the available recording time may be shorter than that specified on the cartridge. Also, the available recording time reduces if the disc is scratched or otherwise damaged, because the damaged sections are made automatically unavailable for recording. (When such a section is detected during recording, "Defect" is displayed and the MD track number is incremented automatically by one.)</p>
<p>Tracks cannot be combined.</p>	<p>The COMBINE function may sometimes be unavailable with a disc which experienced repeated recording and editing. It is not possible to combine a track recorded from the digital input (CD or MD) with a track recorded from the analog input.</p>
<p>Sound heard during forward or reverse search of a recorded track is sometimes interrupted.</p>	<p>Sound heard during search may be interrupted with a disc which experienced repeated recording and editing.</p>

IN CASE OF TROUBLE

When this product is exposed to a strong external noise (including shock, excessive static electricity and abnormal voltage supply due to lightning) or it is operated erroneously, abnormalities such as erroneous display or rejection of any operation may occur. In such a case, use the following procedure to reset the product.

- ① Unplug the power cord from the power outlet.
- ② In 20 to 30 seconds later, plug the power cord again.
- ③ Press the reset button on the top panel once.

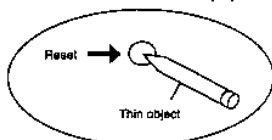

- Pressing the reset button clears all of previously entered data.
- Should the product produces abnormal noise, odor or smoke or a foreign object enters in it, turn power OFF, unplug the power cord and consult your dealer.

DISPLAYED MESSAGES

Message	Meaning	Action To Be Taken
nodISC	<ul style="list-style-type: none"> The CD is not loaded. 	<ul style="list-style-type: none"> Load a music CD.
No Disc	<ul style="list-style-type: none"> The MD is not loaded. The data of the MD cannot be read. 	<ul style="list-style-type: none"> Load a MD. Eject and re-load the MD.
Disc ERR	<ul style="list-style-type: none"> The MD disc is scratched. The MD does not contain TOC or there is an error in the data. 	<ul style="list-style-type: none"> Eject and re-load the MD. Use another MD.
? Disc	<ul style="list-style-type: none"> The data is abnormal. The MD may be out of specifications. 	<ul style="list-style-type: none"> Use another MD.
TOC ERR	<ul style="list-style-type: none"> The MD disc is scratched. The TOC data cannot be read. The MD may be out of specifications. 	<ul style="list-style-type: none"> Use another MD.
DiscFull	<ul style="list-style-type: none"> The MD has no more space for recording. 	<ul style="list-style-type: none"> Use another, recordable MD.
Blank Disc	<ul style="list-style-type: none"> No data has been recorded in the MD. (Neither music or disc name are recorded.) 	<ul style="list-style-type: none"> If you want to play a MD, use a recorded MD.
00:00	<ul style="list-style-type: none"> No music has been recorded in the MD. 	<ul style="list-style-type: none"> Use a recorded MD.
Playback	<ul style="list-style-type: none"> You are attempting to record or edit a playback-only MD. 	<ul style="list-style-type: none"> Use a recordable MD.
Protect	<ul style="list-style-type: none"> The MD is protected against accidental erasure. 	<ul style="list-style-type: none"> Slide the protect tab back to the original position.
TOC Full	<ul style="list-style-type: none"> The MD has no more space for recording the track number and character (disc/track name) data. 	<ul style="list-style-type: none"> Use another, recordable MD.
Can't REC	<ul style="list-style-type: none"> The MD was not recorded correctly due to a shock or disc damage. 	<ul style="list-style-type: none"> Restart recording or use another MD.
Tmp Over	<ul style="list-style-type: none"> The temperature is too high. 	<ul style="list-style-type: none"> Turn the AA-88 OFF and leave it for a while.
Can't EDT	<ul style="list-style-type: none"> Editing is not possible. 	<ul style="list-style-type: none"> Change the stop position and retry editing.
NameFull	<ul style="list-style-type: none"> A disc or track name exceeds 80 characters. 	<ul style="list-style-type: none"> Assign a shorter disc or track name.
Defect	<ul style="list-style-type: none"> Recording is interrupted due to disc scratch. 	<ul style="list-style-type: none"> Use another, recordable MD.
MechaERR	<ul style="list-style-type: none"> The MD mechanism is functioning erroneously. 	<ul style="list-style-type: none"> Press the reset button. Eject the MD and turn the AA-88 OFF.
Can'tCPY	<ul style="list-style-type: none"> You attempt to record signal from a copy-prohibited material. 	<ul style="list-style-type: none"> Use a source from which copy is possible (an ordinary CD, etc.).
NotAudio	<ul style="list-style-type: none"> The disc contains recording of non-audio data. 	<ul style="list-style-type: none"> Play another track. Use another MD.
UTOCWERR	<ul style="list-style-type: none"> The TOC data has not been created correctly due to a shock or disc scratch. 	<ul style="list-style-type: none"> Turn the AA-88 OFF and retry data writing. (Be careful not to apply shock during data writing).
UTOC ERR	<ul style="list-style-type: none"> The recorded TOC data does not match the MD specifications or is otherwise not readable. 	<ul style="list-style-type: none"> Use another MD. Perform all-track ERASE then retry recording.
PIUnlok	<ul style="list-style-type: none"> Normal signal is not input in sync recording. 	<ul style="list-style-type: none"> Set up the CD player and MD recorder again and retry recording.
NotCmplt	<ul style="list-style-type: none"> The MD editing has not completed normally. 	<ul style="list-style-type: none"> Retry the same operation again.
TrckPERR	<ul style="list-style-type: none"> You attempt to record or edit a playback-only track. 	<ul style="list-style-type: none"> Record or edit another track. Use another MD.
EPROMERR	<ul style="list-style-type: none"> The MD recorder is functioning erroneously. 	<ul style="list-style-type: none"> Eject the MD and turn the AA-88 OFF.
Error	<ul style="list-style-type: none"> Other error than above is produced. 	<ul style="list-style-type: none"> Turn the AA-88 OFF and retry the same operation.

SPECIFICATIONS

Mixer Block

Inputs

PHONO	x 2 systems
LINE stereo	x 4 systems
MIC	x 2 systems

PGM sources x 3

Cross-faders Detachable CF-RG/PGM 1 to 3

Tone controls

BASS	80 Hz \pm 10 dB
MID	500 Hz \pm 10 dB
TREBLE	8 kHz \pm 10 dB

Input rating

PHONO	3.1 mV/40 k Ω
LINE	280 mV/13.5 k Ω
MIC	3.1 mV/5.4 k Ω
INST	70 mV/35 k Ω

Output rating

MIXER OUT	970 mV/1.1 k Ω
HEADPHONE	100 mW + 100 mW (150 Ω)

CD Player Block

Disc	12 cm or 8 cm
Sampling frequency	44.1 kHz
Error correction	CIRC
High-frequency distortion	Below 0.05%
S/N ratio	98 dB

Power Amplifier Block

Output level	15 W + 15 W (8 Ω)
Frequency response	20 Hz to 20 kHz
S/N ratio (A network)	76 dB
High-frequency distortion	0.05%

FM/AM Tuner Block

Tuning system Electronic tuning

Receiving frequencies

FM	87.5 MHz to 108 MHz
AM	531 kHz to 1602 kHz

Frequency response

FM	30 Hz to 10 kHz
AM	100 Hz to 2 kHz

MD Recorder Block

High-frequency distortion (playback)	0.1%
S/N ratio (analog recording/playback)	85 dB

General

Power supply	AC 230 V 50 Hz
Power consumption	60 W
Dimensions	468W x 153.5H x 388.5D mm
Weight	11.4 kg

Accessories

Instruction Manual

Design and specifications are subject to change without notice.

US and foreign patents licensed from Dolby Laboratories Licensing Corporation.